

Technical sheet :

MT 733 EASY



 **MANITOU**
HANDLING YOUR WORLD

Capacities		Metric
Max. capacity		3300 kg
Max. lifting height		6.90 m
Maximum outreach		3.90 m
Breakout force with bucket		5770 daN
Weight and dimensions		
Overall length to carriage	l11	4.74 m
Length to face of forks	l2	4.74 m
Overall width	b1	2.33 m
Overall height	h17	2.30 m
Wheelbase	y	2.81 m
Ground clearance	m4	0.45 m
Overall cab width	b4	0.89 m
Tilt-up angle	a4	12 °
Tilt-down angle	a5	114 °
External turning radius (over tyres)	Wa1	3.80 m
Unladen weight (with forks)		6700 kg
Overall weight		6700 kg
Tires type		Inflatable
Standard tires		Alliance 400/80 - 24 - 162A8
Forks length / width / section	l / e / s	1200 mm x 125 mm x 45 mm
Performances		
Lifting		8.30 s
Lowering		6 s
Extension		7.30 s
Retraction		4.50 s
Crowd		3.40 s
Dump		2.80 s
Engine		
Engine brand		Deutz
Engine norm		Stage V, Tier 4 final
Engine model		TD 3.6 L
Number of cylinders / Capacity of cylinders		4 - 3621 cm³
Engine power (Hp/kW)		75 Hp / 55.40 kW
Max. torque / Engine rotation		340 Nm @ 1600 rpm
Drawbar pull (Laden)		8360 daN
Transmission		
Transmission type		Torque converter
Number of gears (forward / reverse)		4 / 4
Max. travel speed		24.90 km/h
Max. travel speed (may vary according to applicable regulations)		25 km/h
Parking brake		Manual
Service brake		Oil-immersed multi-discs braking on front & rear axles
Axle Manufacturer		Dana
Hydraulics		
Hydraulic pump type		Gear pump
Hydraulic flow / Pressure		92.70 l/min-260 bar
Tank capacities		
Engine oil		10 l
Hydraulic oil		128 l
Hydraulic tank capacity		10 l
Fuel		120 l
Noise and vibration		
Noise at driving position (LpA)		79 dB
Noise to environment (LWA)		104 dB
Vibration on hands/arms		2.50 m/s²
Miscellaneous		
Steering wheels (front / rear)		2 / 2
Drive wheels (front / rear)		2 / 2
Safety / Cab certification		Standard EN 15000 / Cabin ROPS - FOPS level 2
Controls		JSM

MT 733 Easy - Dimensional drawing

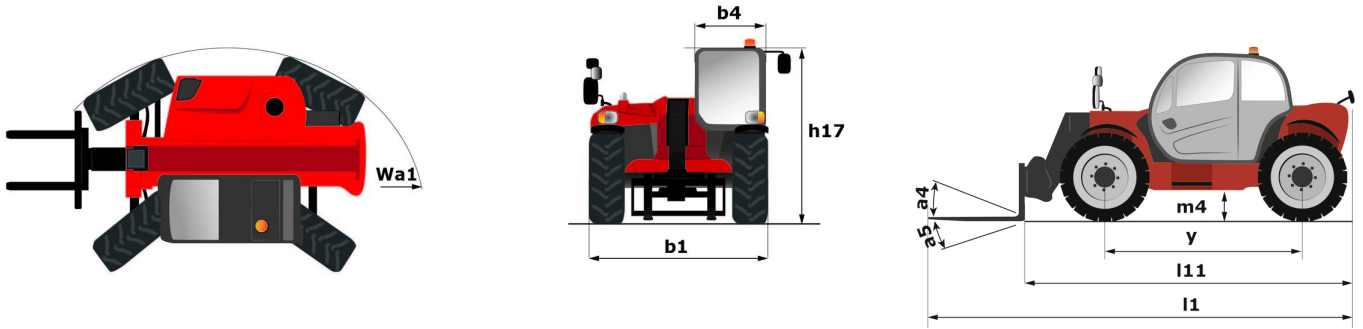

MT 733 Easy - Load chart

Machine on tires with forks Metric

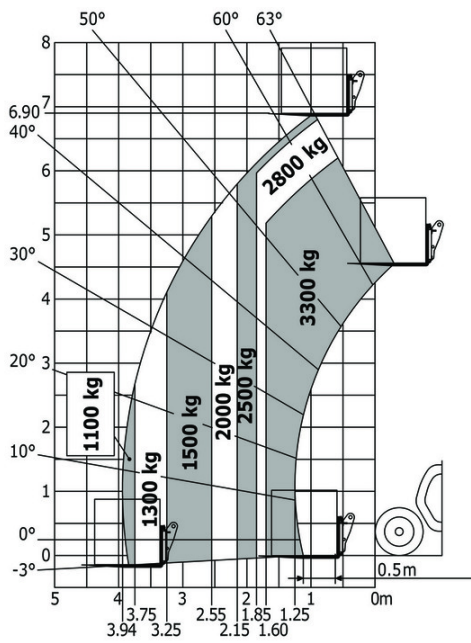



Head Office

B.P. 249 - 430 rue de l'Aubinière

44150 Ancenis Cedex - France

Tel: +33 (0)2 40 09 10 11 - Fax: +33 (0)2 40 09 10 97

www.manitou.com



This publication provides a description of the configuration versions and options for Manitou products, which may differ for equipment. The equipment presented in this brochure may be part of a series, as an option, or it may not be available, depending on the versions. Manitou reserves the right, at any time and without notice, to amend the specifications described and represented. The specifications provided do not bind the manufacturer. For more details, please contact your Manitou agent. This is not a contractually binding document. The presentation of the products is not contractually binding. List of specifications non-exhaustive. The logos as well as the visual identity of the company are owned by Manitou and cannot be used without authorisation. All rights reserved. The photos and diagrams contained in this brochure are only provided for consultation and information purposes.

MANITOU BF SA - Limited company with board of directors - Share capital: 39,668,399 euros - 857 802 508 RCS Nantes